

CARDET-101 Installation Manual

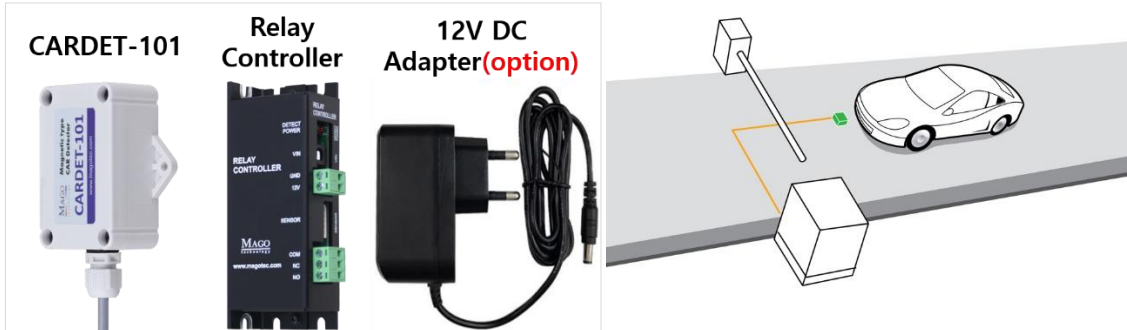

- ☑ **CARDET** makes the **MAGNETIC MAP on the spot** around the sensor
So **DO NOT TOUCH or MOVE** the sensor when it operates.

MAGO technology
2024.09.05 revision

1. Installations

CARDET is the acronym of CAR DETECTION, which is an innovative solution for non-contact vehicle detection using magnetic measurement and signal processing.

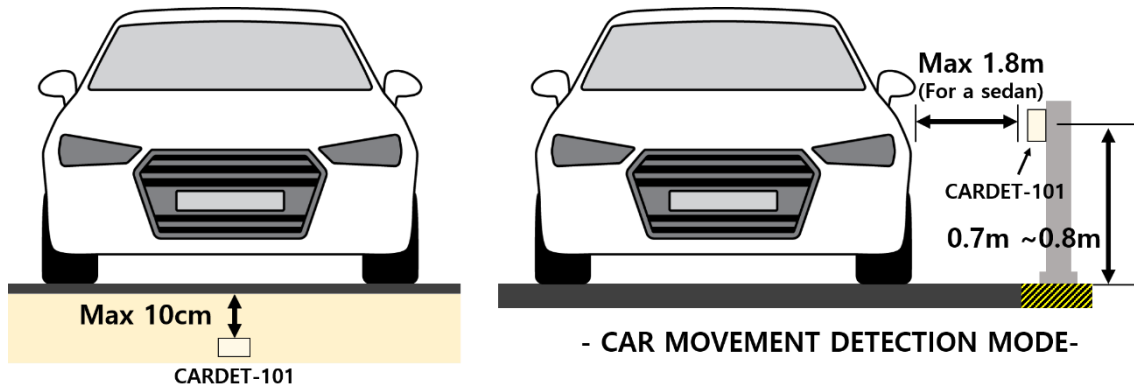

<Fig.1 Installations of **CARDET-101**>

CARDET-101 sensor should be fixed on a stable supporter, and the installation height will be good at **70-80cm** from the surface of the road. **CARDET-101** sensor can also be installed under the surface of the road (Max.10cm.)

CARDET-101 forms an all-directional detection space such as a blue sphere in Fig.2. The maximum distance for detecting between the sensor and a full-sized sedan is **1.8m** when it operates in **CAR MOVEMENT DETECTION** mode. When it operates in **CARDET EXISTENCE DETECTION** mode, the maximum distance will be **1.5m**. For an economy car, the max distance can be reduced about 10%.

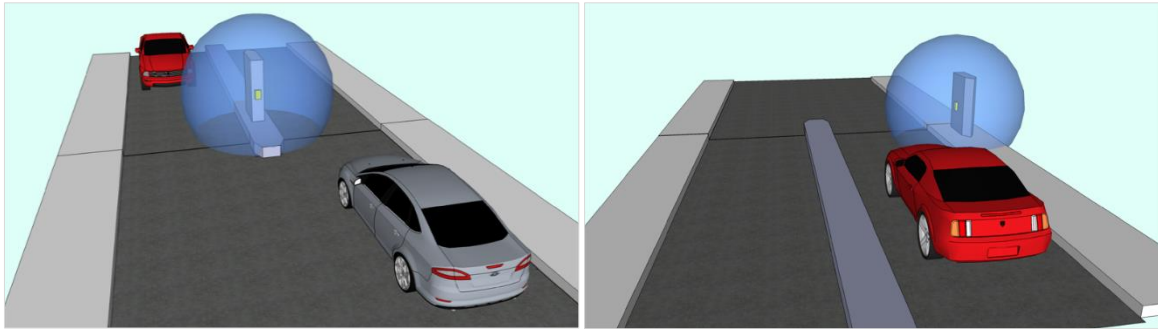

<Fig.2 detecting cars (LEFT: both way, RIGHT: one ways) >

2. Sensor Interface

Fig.3 shows the picture of the relay controller for **CARDET-101**, the relay controller use **DC 12V** for the power supply, user can use a standard **DC 12V** adaptor (5.5 pi jack).



<Fig. 3 CARDET relay controller>

☑ The max capacity of the **power supply** should be **more than 1A**.

If user wants to extend the cable between the sensor head and relay controller more than 80m, then user should use an adaptor that has a bigger current capacity. Please check the supply voltage drop inside sensor head (12V) for the case of the cable extension.

The relay controller has a RELAY that makes it easy to interface a **CARDET** to user's device. The RELAY has a following maximum electrical capability (table 1). Users can use both of **AC** and **DC** to the RELAY.

<Table 1 maximum electrical capability of the RELAY on the relay controller >

	Max voltage	Max current	Max power
DC	30V	3A	90W
AC	220V	2A	440W

Here are two connection examples of the relay controller, the dry contact (RELAY) will enable you to interface easily our sensor to your system.

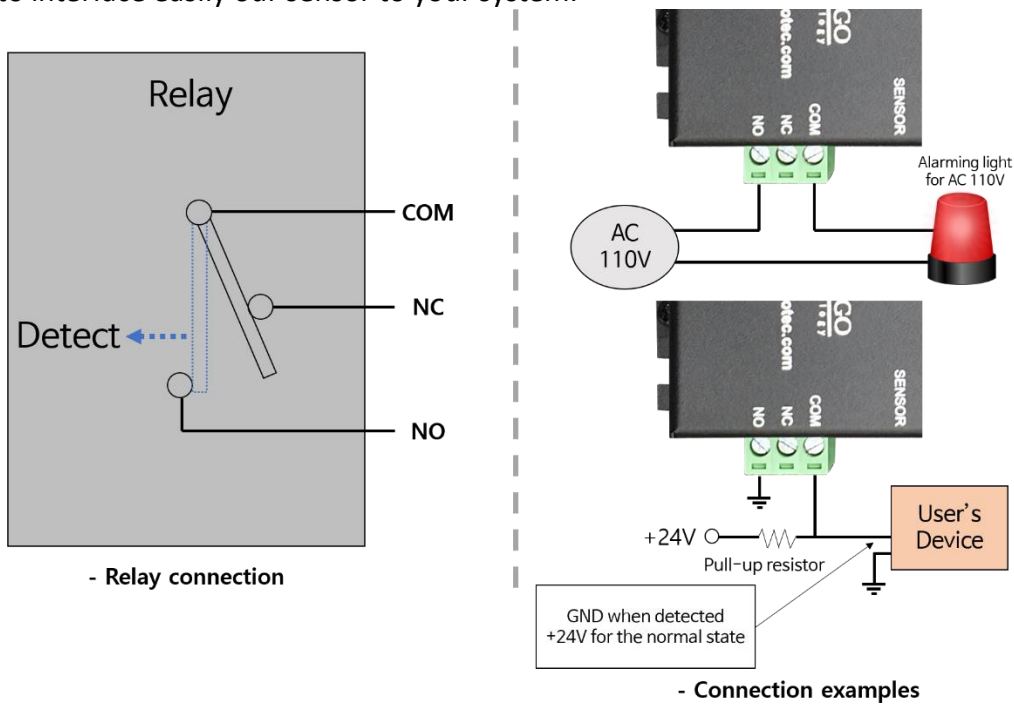

<Fig.4 Two examples of interconnection>

3. CARDET-101 Sensor output

If you open the upper cover of **CARDET-101** sensor module, then you can find a DIP S/W and a small volume as following.

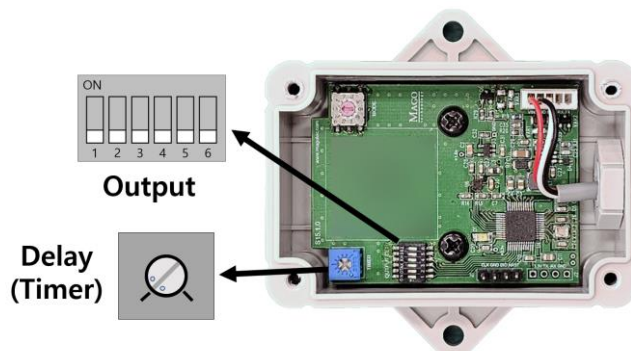

<Fig.5 Default setting of the DIP S/W >

User can choose the operation mode of the sensor. Basically, the default setting of **CARDET-101** will work well almost all environment, so do not change the DIP S/W unless necessary.

3.1 Setting of the sensor output mode

The first and second toggles in DIP S/W is to select the sensor output modes among 4 functions. **CAR EXISTENCE** mode means that the sensor detects whether a car is in the sensing area or not, and in **CAR MOVEMENT** mode CARDET detects the movement of a car in the sensing area. Table 2 shows that the output characteristics of 4 modes.

<Table 2 Setting of the output mode >

DIP S/W	Detection Mode	Sensor Output Description
	CAR EXISTENCE	Output is ON during a car is detected in the sensing area (default). OFF time delay can be adjusted by the volume on the PCB (0-10sec.)
		Output is ON with a fixed time when a car is detected. The width of the ON pulse can be adjusted by the volume (0.1 ~ 60sec.)
	CAR MOVEMENT	Output is ON during a car is moving in the sensing area. OFF time delay can be adjusted by the volume on the PCB (0-10sec.)
		Output is ON with a fixed time when a car is moving in the sensing area. The width of the ON pulse can be adjusted by the volume (0.1 ~ 60sec.)

The third, forth toggle in DIP S/W is reserved for future use.

3.2 Setting of the sensitivity

The last two toggles are for adjusting the magnetic sensitivity of CARDET. If there is a large size of magnetic noise nearby, please change it to an insensitive setting.

<Table 3 Setting of the sensor sensitivity of CARDET-101 >

DIP S/W	Sensitivity	Remark
	Sensitivity 4	Least sensitive
	Sensitivity 3	-
	Sensitivity 2	DEFAULT
	Sensitivity 1	Most sensitive

Sensor should be reset if the DIP s/w setting is changed.

4. Sensor Initialization

When a **CARDET-101** is powered on, the sensor executes the automatic calibration on the spot (approx. 1 sec.), so when user turn on the power switch, there is no cars or magnetic disturbance. If the sensor moves when it works, then it should make re-calibration (turn-off and turn-on). During the calibration (about 1 sec.) the relay output is ON.

5. Warning

CARDET-101 measures the variation of Earth magnetic field, so it might make an incorrect operation against severe electromagnet noises, motorcycles, a large size truck, a motor beside the sensor, etc. User should design the whole system will be safe even if the sensor makes a false operation. There is no responsibility for the makers and distributors for safety issues.

6. Specification

<Table 4 specification of CARDET-101 sensor head>

CARDET – 101 Sensor Specification					
Characteristics	Min.	Typical	Max.	Unit	Remark
Power supply		12		Volt	
Current consumption		35		mA	Sensor head only
Operation temp.	-20		+85	Degree	
Detection distance from the sensor head	0.1	1.2	1.8	m	Max 1.8m for a sedan (MOVEMENT detection mode)
Max. cable distance			80	m	Case of 1 A (DC12V)

Please contact to sales@magotec.com