

CARDET-LD Installation Manual

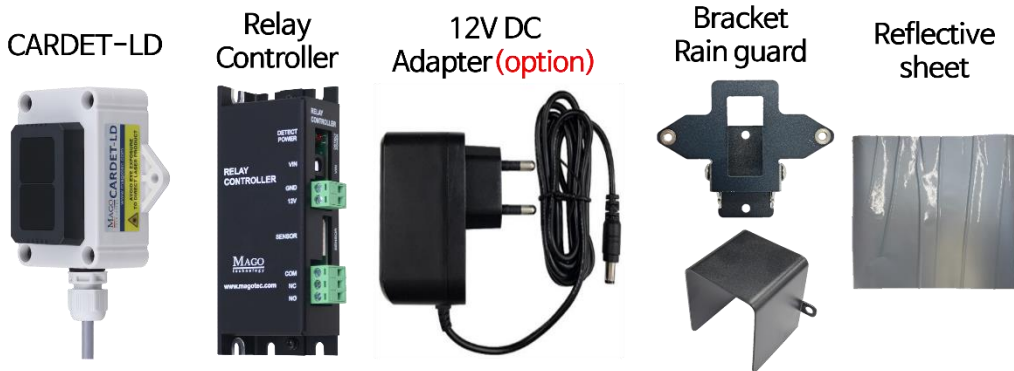

MAGO Technology
2022.10.19 revision

1. CARDET-LD overview

- CARDET-LD can detect all the coming objects reaching the line between sensor and the fixed reflector or the aimed floor. CARDET-LD is a digital sensor that uses TOF (Time of Flight) principle with a pulsed LASER.
- CARDET-LD model has the state-of-the art digital filtering structure that cancel out the noises coming from various sources on a road, and it also has the adaptive algorithm for the change of environment. It is a very clever smart sensor easy to install and it does not need a complex sensor setting.

2. Installation of a CARDET-LD

The sensing direction of a CARDET-LD is as Fig. 1, and it detects the vehicle that reach the line between the sensor and reflection point. The maximum sensing distance is 15 meters.



Fig. 1. Sensing direction of a CARDET-LD

CARDET-LD sensor can be installed in two ways as follows.

CASE 1: If you have a fixture across the road, then the sensor can be installed as **Fig. 2**. Place the reflection sheet where the spot that **CARDET-LD** sensor aimed (you can use your presentation laser pointer for the check the position). **The maximum distance** between sensor and the reflection sheet is **15 meters**.

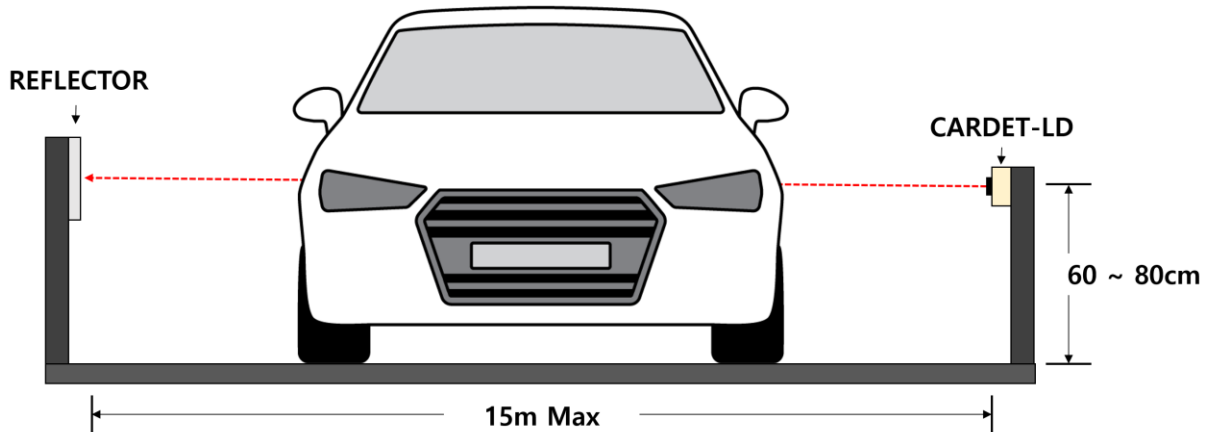

Fig. 2. CASE 1 of the Installation

CASE 2: If you don't have a fixture across the road, then incline the direction of the sensor aim using the bracket and set the angle of **CARDET-LD** as **Fig. 3**. Do not exceed the maximum distance of **4 meters** horizontally from the sensor location.

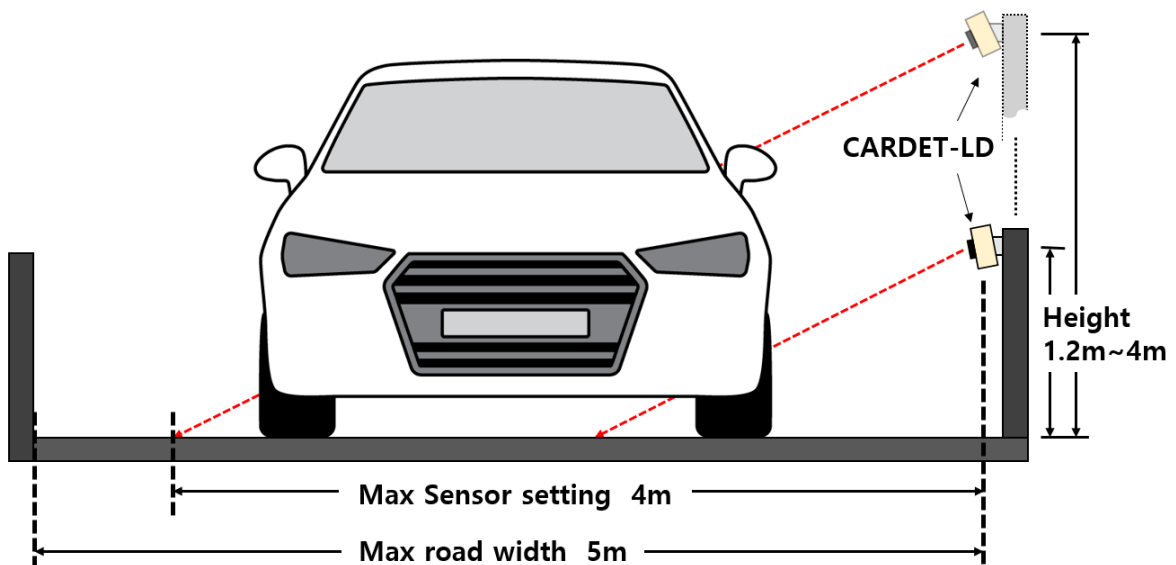
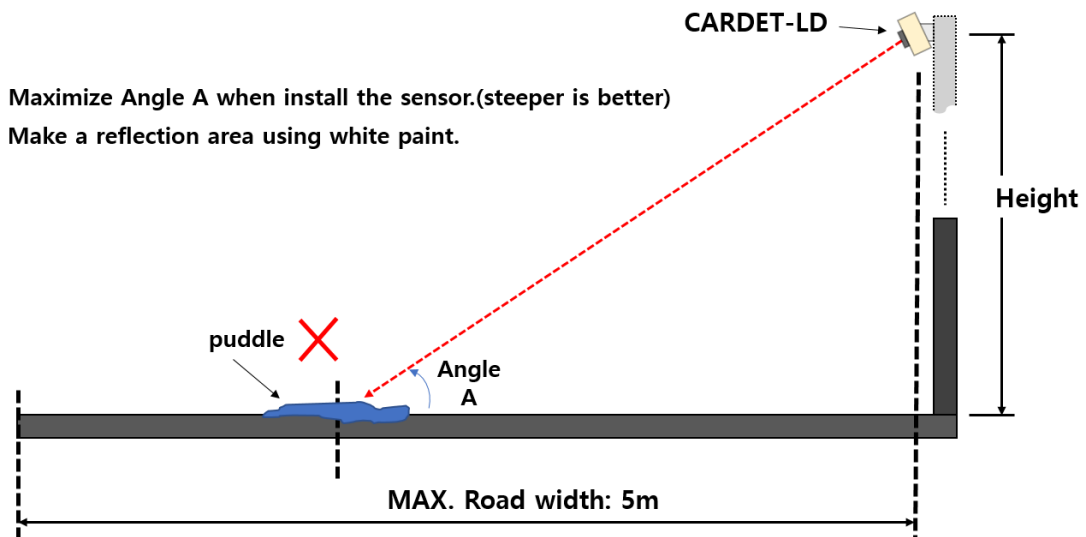

Fig. 3. CASE 2 of the Installation

❖ Installation with an angle



- Please set the height of sensor as high as possible.
- Puddle at the reflection area may cause performance degradation.

❖ Multi sensor installation

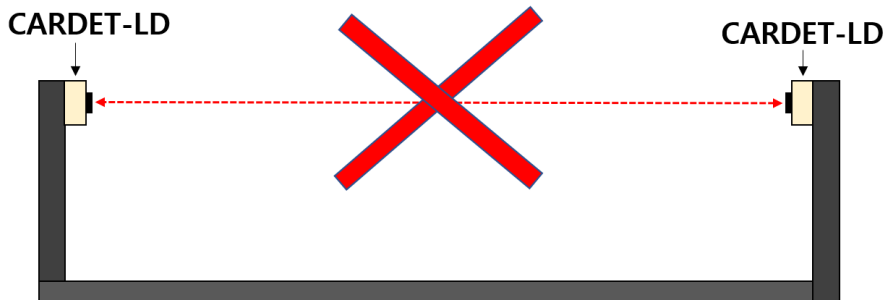

- Do not install two LD sensors face to face.
- Installation of two LD's must be at least 1m away from the sensor's beam line.

2.1 Installation of the bracket & rain guard

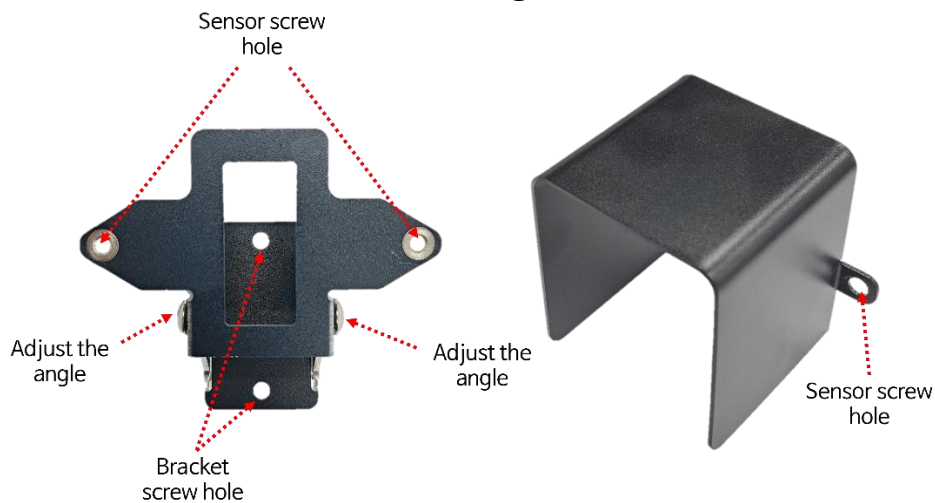

- ① Fix the angle bracket to the wall or pillar using the supplied direct screw.
- ② Put the rain guard on the sensor and adjust it so that the sensor and the fixing screw hole coincide.
- ③ After inserting the spring washer into the fixing screw, fix it by aligning it with the fixing screw hole.
- ④ After adjusting the angle, tighten the angle adjusting screw as hard as possible so that it does not move.

3. Cautions

- ① Please align exactly the sensor direction to the reflector sheet. There is a possibility of false operation when the reflector sheet is not attached or incorrectly aimed. The problem that occurred by false installation or misuse is not responsible to the manufacturer or seller.
- ② Please install a **CARDET-LD** excluded the direct rays of the sun. If user want to use an extra case for the sensor, then the LENS of the sensor should be exposed out of the case.
- ③ Please tighten the nut of cable gland on the sensor before installation.
- ④ Even a **CARDET-LD** use safe LASER Module (Class 1 laser product), but **do not stare into beam or view directly with optical instrument.**

4. Sensor Interface

Fig.4 shows the picture of the relay controller for **CARDET**, the relay controller use **DC 12V** for the power supply, user can use a standard **DC 12V** adaptor (5.5 pi jack).

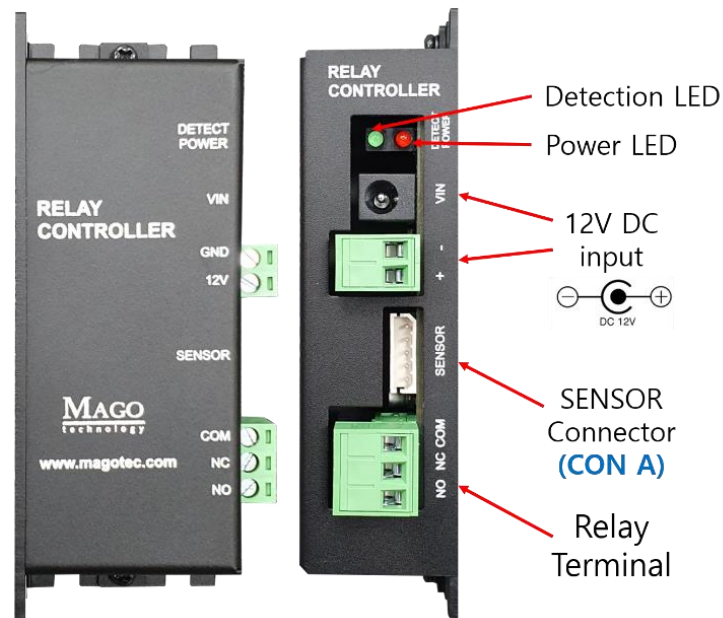

Fig. 4 CARDET Relay controller

☑ The max capacity of the power supply should be **more than 1A**.

If user wants to extend the cable between the sensor head and relay controller more than 80m, then user should use an adaptor that has a bigger current capacity. Please check the supply voltage drop inside sensor head (12V) for the case of the cable extension.

The relay controller has a RELAY that makes it easy to interface a **CARDET** to user's device. The RELAY has a following maximum electrical capability (table 1). Users can use both of **AC** and **DC** to the RELAY.

Table 1 maximum electrical capability of the RELAY on the relay controller

	Max voltage	Max current	Max power
DC	30V	3A	90W
AC	220V	2A	440W

Here are two connection examples of the relay controller, the dry contact (RELAY) will enable you to interface easily our sensor to your system.

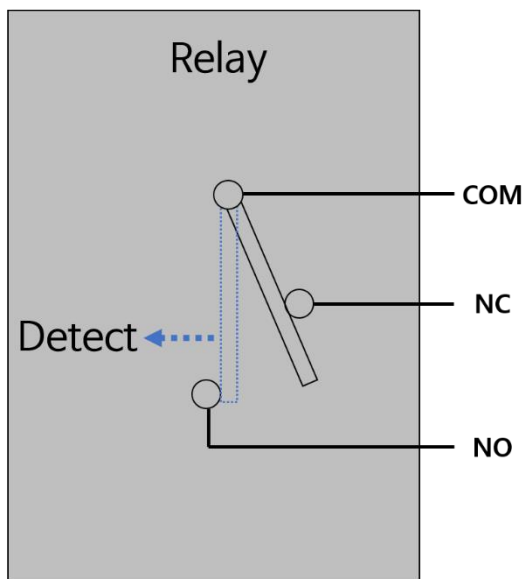

- Relay connection

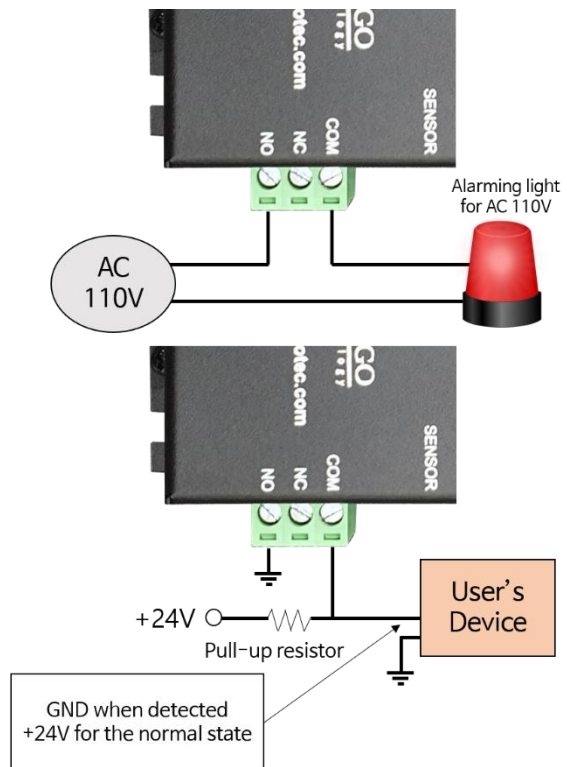

- Connection examples

Fig.5 Two examples of interconnection

5. Adjusting parameters of CARDET-LD



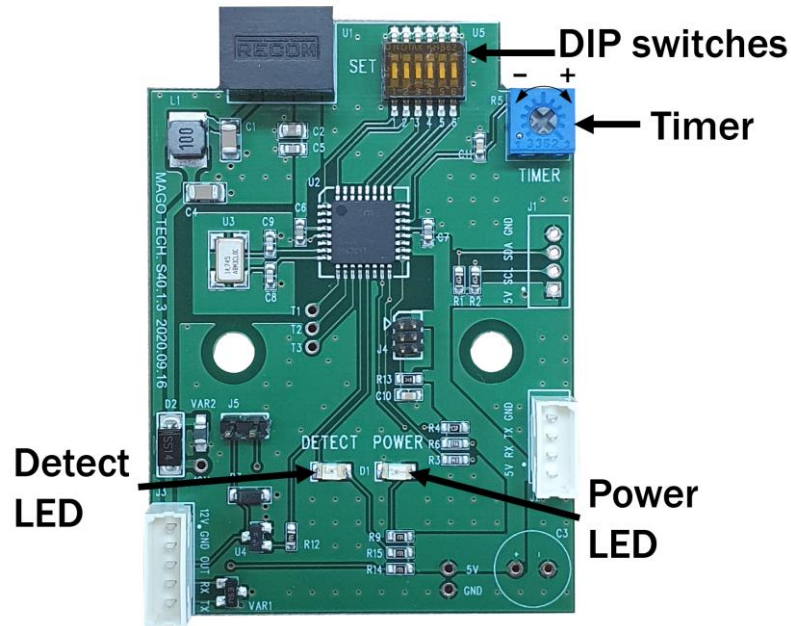

The operation of a CARDET-LD with the default setting is;

The RELAY (relay controller) is ON during a vehicle detected.

❖ Please change sensor setting **only** if it should be adjusted.

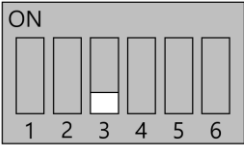
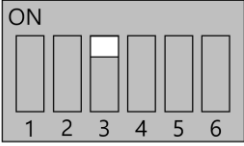
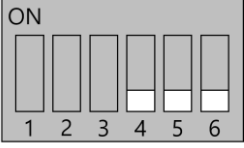
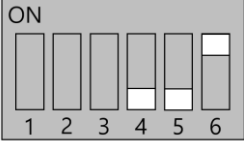
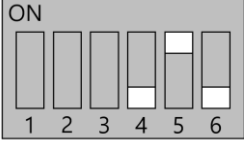
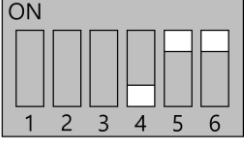

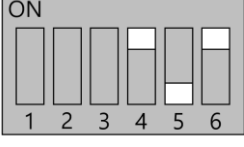
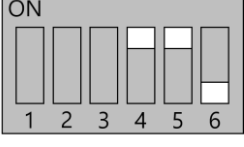
Number	parameters	ON / OFF set	Operation
1	Sensitivity		Default sensitivity
			Low sensitivity
2	Output Setting		<p>OUTPUT is ON during a vehicle detected (default) (OFF delay 0 sec. ~ 10 sec.)</p>
			<p>OUTPUT is a constant PULSE (PULSE width 0.3 sec. ~ 60 sec.)</p>

3	AI Environmental adaptation algorithm		Adaptation speed is default.
			Fast adaptation speed.
4-6	Detection Speed		Detection Speed (150ms, default)
			Detection speed (70ms)
			Detection speed (350ms)
			Detection speed (450ms)
			Detection speed (650ms)
			Detection speed (950ms)
			Detection speed (1350ms)
			Detection speed (2050ms)

6. Specification

TABLE 3. CARDET-LD sensor specification

CARDET – LD Sensor Specification					
Characteristics	Min.	Typical	Max.	Unit	Remark
Power supply		12		Volt	
Current consumption		90		mA	Sensor head only
Operation temp.	-20		+60	°C	
Initial boot time		1.0		sec.	Once after power on
Detection distance from the sensor head	0.2		15.0	m	
Minimum installation distance	1			m	
Max. cable distance			80	m	with 12 W power adapter

Please contact to MAGO Technology, sales@magotec.com