

CARDET-LD100 USER MANUAL

(Dedicated for LPR system)

MAGO Technology

2025.11.05 revision

Sensor Overview

- **LD100** is a vehicle detection sensor using Pulsed LASER technology. Unlike infrared sensors, it is unaffected by sunlight and uses the Time of Flight (**TOF**) method to detect a vehicle.
- **This model is specialized for LPR** (License Plate Recognition) systems and can be easily mounted on the body of LPR units.
- Unlike standard LD models, the **LD100 does not require a reflector** and is optimized for approach detection only, thus it does not maintain output during vehicle stop.



Product component

CARDET-LD100



Relay
Controller



Bracket
Rain guard



12V DC
Adapter (Optional)



Installation

(A) For LPR mode

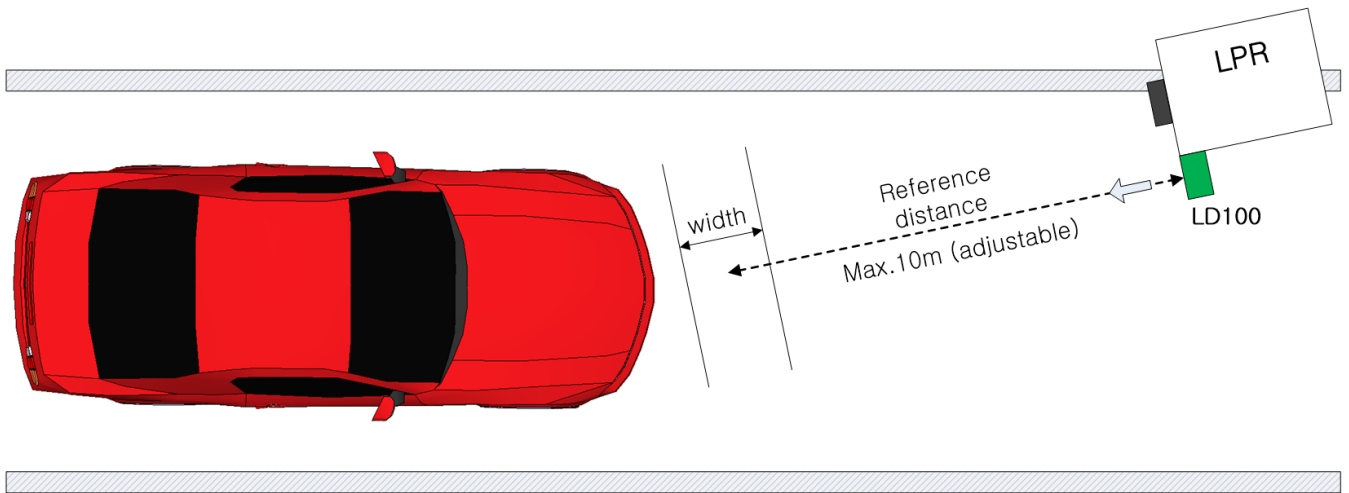

- Mount the sensor facing the front of incoming vehicles with license plates (Height: **60–80 cm**).
- Configure the rotary switch and DIP switches to set the **detection mode, reference distance, and width**. (Default: **LPR mode, 3m reference, ±20cm width**)
- When a vehicle enters the detection zone, the output **turns ON for a preset duration**.

(B) For Beacon Light Mode

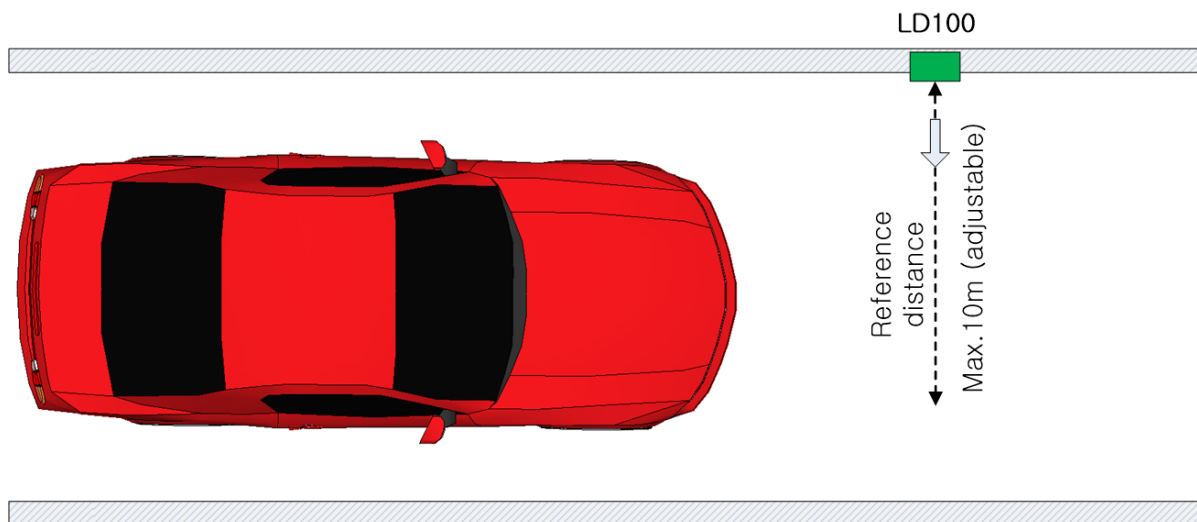

- Install the sensor perpendicular to the side of incoming vehicles (Height: 60–80 cm).
- Set the mode and reference distance via the rotary and DIP switches. (Switch to beacon mode and adjust detection range.)
- For beacon mode, (**0.1 ~ reference distance**) will be the detection zone.
- Output turns ON for a preset time when a vehicle enters the detection zone.

(C) Cautions

- **Do not** install multiple LD sensors **directly facing each other** as interference may occur. Maintain a minimum distance of 1 meter between beam lines.
- **LD100** is a **Short Pulse (LPR-only) model**. If the function of signal retention during vehicle stop is required, use a standard LD model.

Bracket and Rain Shield Installation

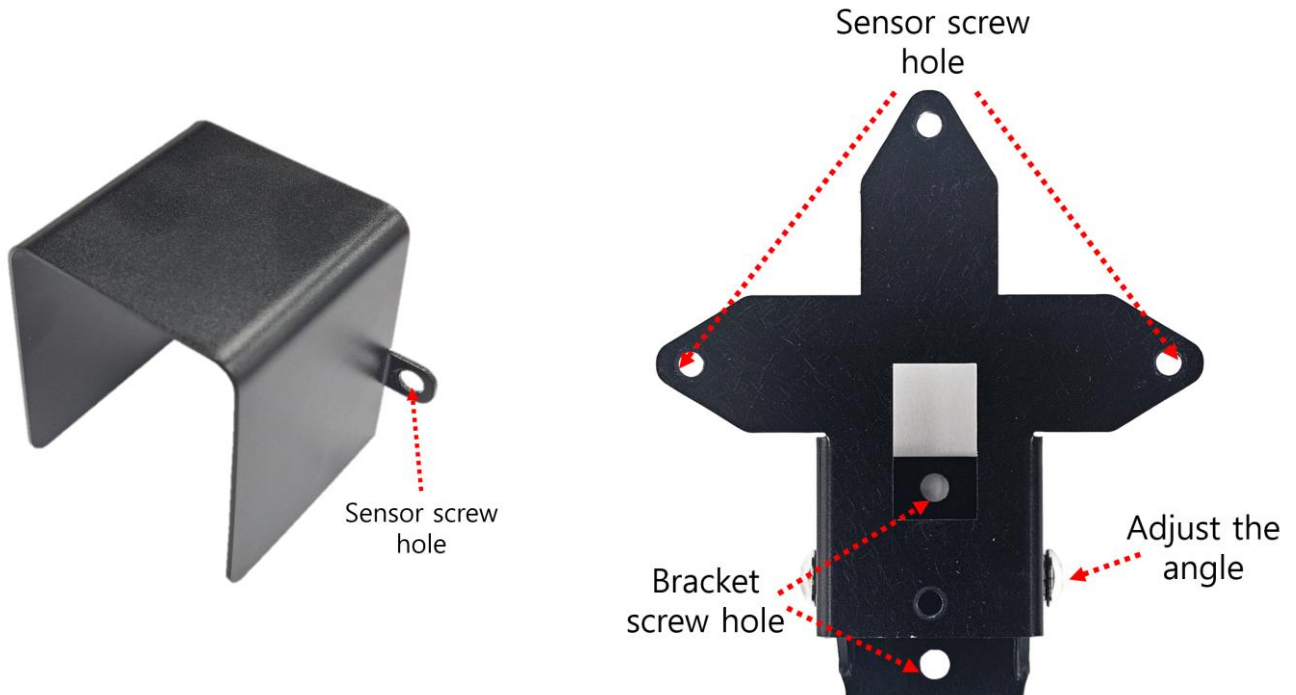

- Secure the **angle bracket** to a wall or pole using the included screws.
- Attach the **rain shield** to the sensor and align the mounting holes.
- Insert the spring washer into the mounting screw, align with the hole, and tighten firmly.
- After adjusting the angle, firmly fix the angle adjustment screw to prevent movement.

Relay Controller Connection

- Connect the sensor output terminal to connector (**CON A**) and connect a **12V** power adapter. The sensor will boot in about 1–3 seconds and begin detection.
- Use the relay contacts (dry contact) to control external devices. **COM** is connected to **NC** (Normally Closed) when idle, and to **NO** (Normally Open) **when a vehicle is detected**.

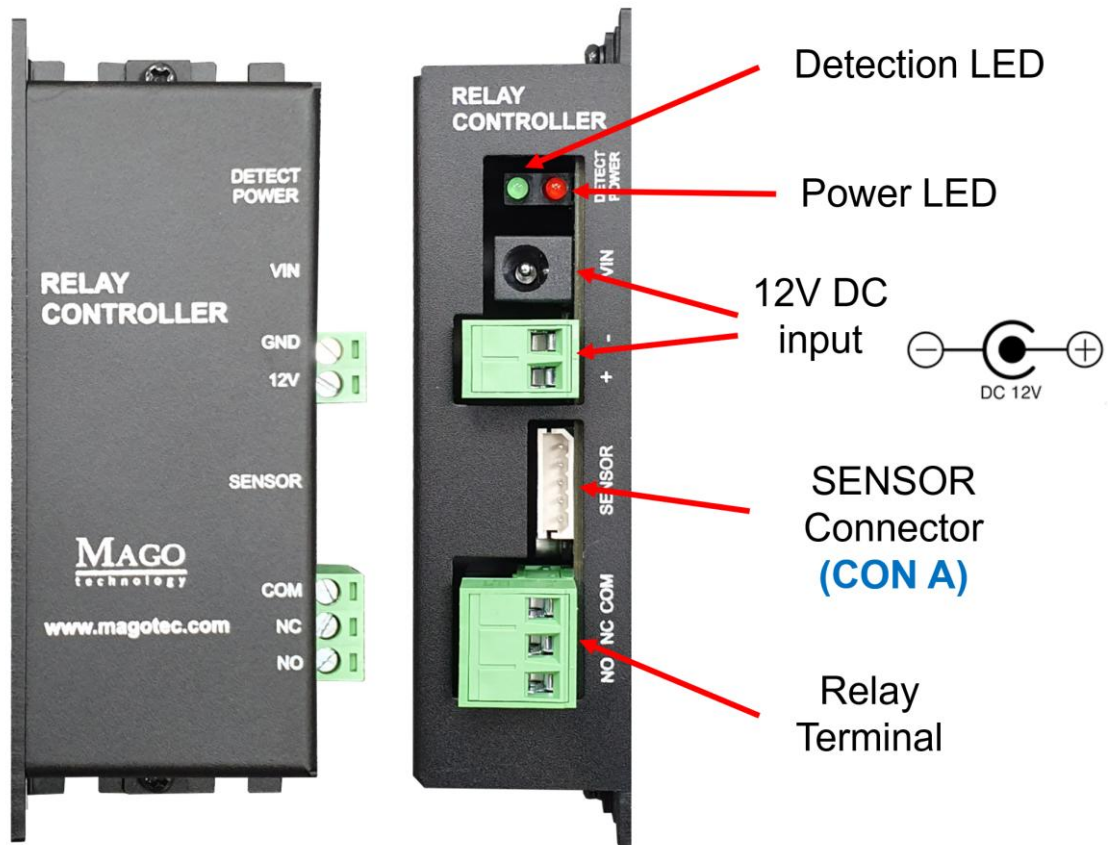

- Ensure voltage, current, and load capacity **do not exceed the maximum values**. The manufacturer is not responsible for damage due to overcurrent or wiring faults.

Load	Max. Voltage	Max. Current	Max. Capacity
DC	30V	3A	90W
AC	220V	2A	440W

- When connecting to an external device or beacon, use the **COM** and **NO** terminals with external power. The example diagram is for reference only. Operation is not guaranteed under all environments.

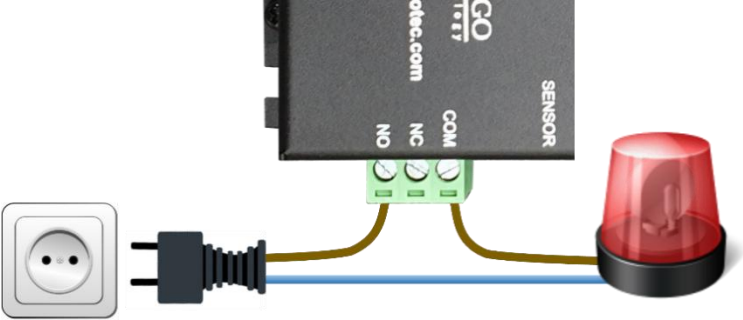
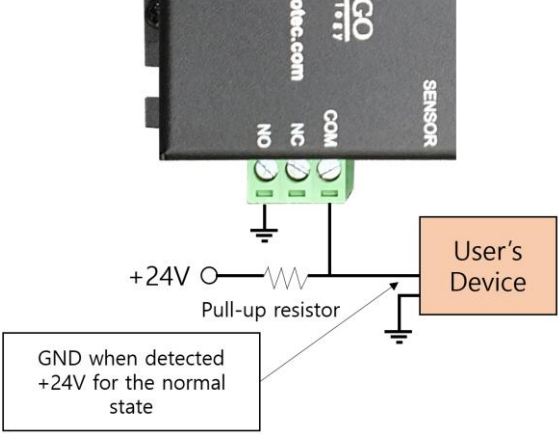
examples	description
<p data-bbox="320 421 475 499">220V Beacon light</p>	
<p data-bbox="268 904 523 1025">Connection to user's device with pull up resistor</p>	 <p data-bbox="679 1122 938 1211">GND when detected +24V for the normal state</p>

LD100 Configuration

- Open the sensor case to configure operation mode, reference distance and width, and also timer settings.
- Always power off the sensor before making changes, and **reset power after configuration.**

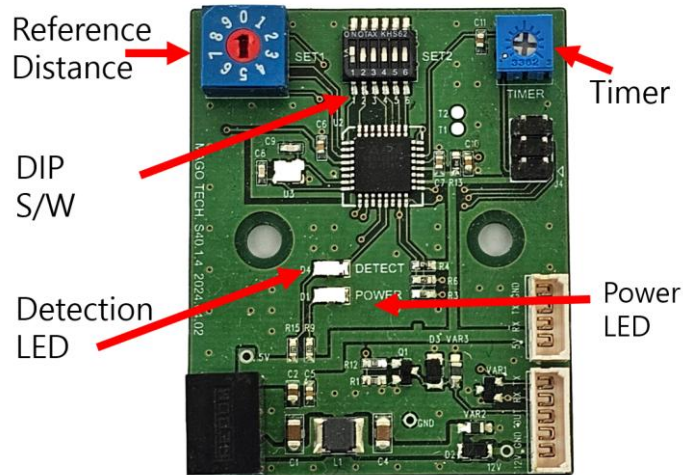

❖ Reference Detection Distance Setting

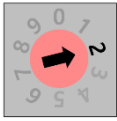
	Number	Reference detection distance
Setting distance Rotary S/W  Default: 2	0	2m
	1	2.5m
	2	3.0m (default)
	3	3.5m
	4	4.0m
	5	4.5m
	6	5.0m
	7	6.0m
	8	8.0m
	9	10.0m

❖ Timer Settings

	Mode	On pulse duration (Short Pulse)
	LPR	Output ON time = 0.3 to 2 sec
	Beacon	Output ON time = 0.3 to 30 sec

*Note: **LD100** does not support signal retention during vehicle stop.

❖ DIP S/W Settings

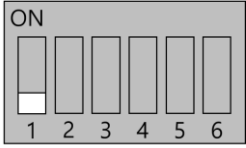
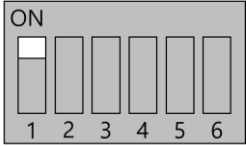
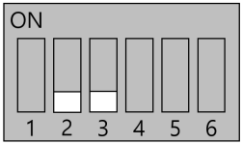
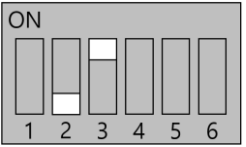
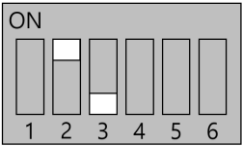
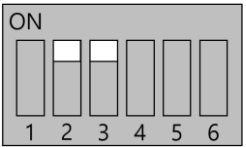
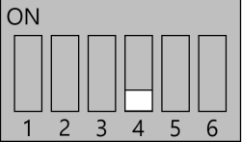
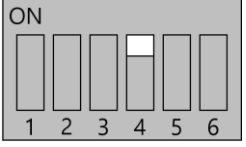
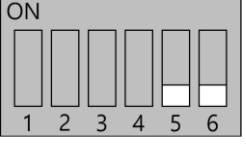
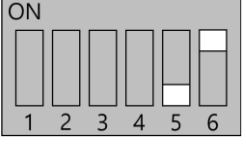
	ON / OFF	Description
Mode		<p>LPR mode (Short pulse): Detection range: (reference distance ± width)</p>
		<p>Beacon mode (Short pulse): Detection range: (0.1~ reference distance)</p>
Detection range		width: ±20cm
		width: ±10cm
		width: ±30cm
		width: ±40cm
Output Re-loading Time		Reloading time for next detection: 1 sec.
		Reloading time for next detection: 0.5 sec.
Minimum detection time for output		Min. detection time for output: 30ms
		Min. detection time for output: 20ms

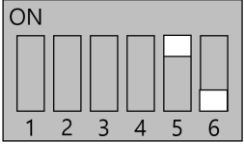
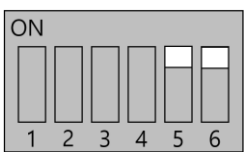
	Min. detection time for output: 50ms
	Min. detection time for output: 100ms

❖ The minimum detection time is the duration required for the sensor’s output to switch to ON.

Specification

Supply Voltage	12V
Current Consumption (Sensor head)	90mA
Temperature	-20 ~ 60°
Booting time	1~3 sec.
Min. distance between sensor and car	0.3m
Detection range	0.3m ~ 10m
Cable length for the sensor head	Max. 80m (Using 1A adaptor)
LASER class	CLASS 1

Safety Precautions

- Warranty: 1 year from shipment (excluding user error and natural disasters).
- The sensor may malfunction due to fog, environmental factors, or improper installation. The manufacturer is not responsible for such issues.
- Do not look directly into the laser sensor.

Technical Support

+82-70-4065-6397, sales@magotec.com